



## NC-UV0609PEIII-II

### High Cost Performance Digital Inkjet Printer

NC-UV0609PEIII-II is a flow product of Nocai UV0609 series. This machine has the advantages of high cost performance, diverse functions and strong stability, and is very suitable for small batch production needs. The application scenarios are diverse and suitable for industries such as advertising, gifts, stationery, handicrafts, and packaging.



# Features



## High precision and durable print head

Epson I1600-U1 uses a unique MEMS technology manufacturing process to achieve high-precision nozzle arrangement. The unique VSDT (Variable Ink Droplet Technology) can freely control the size of the ejected ink droplets, presenting more picture details, smooth color transition, and high saturation.



## 180mm print height

It supports product thicknesses of 0-180mm, meeting the printing needs of products of different thicknesses, without material restrictions, and has a wide range of applications.



## One machine with multiple uses for individual needs

One machine has multiple functions. It can be equipped with an electric cylinder jig to achieve 360-degree rotation printing. It can print mugs, thermos cups and other cylindrical products to meet diverse personalized needs.



## Humanized design and easy operation

Telescopic control panel, easy to operate. The control panel has various functions and the display is simple and easy to understand. Commonly used functions such as testing, cleaning, and stopping are all available with one click.

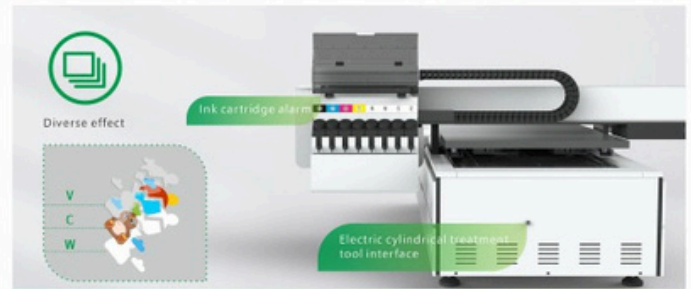

## Diversified effects, one-time molding

A variety of color combinations, four colors + white + varnish, with diversified effects and no color restrictions. Color, color white, embossed varnish and other printing can be printed in one time.



## Strong stability, green and environmental friendly

The design of the lifting and lowering ink station accurately controls the head position and comprehensively protects the print head. Using UV ink, bright colors, green and environmentally friendly.



## Fine design, pursuit of perfection

The high-precision honeycomb hard air-suction aluminum platform is used to allow the product to be adsorbed flatly on the platform to ensure the printing effect. The printing format is 60\*90cm, which is very suitable for small batch production.



## Safety, worry-free and quality assurance

The print head is equipped with an intelligent touch and anti-collision sensing device. The ink truck automatically stops after being touched, thus protecting the print head and printing materials.



# Industry application and effect display



## DTF effect

Use a UV printer to print on the crystal label A film, use a laminating machine to transfer the B film together at high temperature, and the crystal label can be formed.

The crystal label process is not limited by material or product shape, and can be pasted on various materials, such as wood, acrylic, ceramics, glass, metal, plastic, etc., and is widely used.



## Frosted effect

Print colors directly on transparent/white materials to create a matte effect.

Product applications: cards, personalized gift lamps, customized glass sheets, transparent plastic films, motorcycle glass displays, ceramic cups, etc.

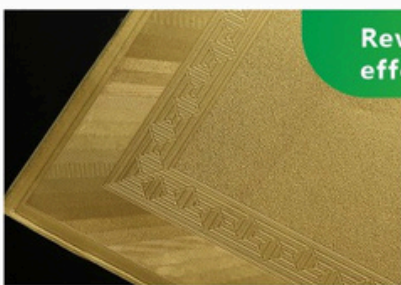

## Reverse varnish effect

By controlling the amount of light ink and the frequency of UV light, you can print a reverse varnish effect.

The use of reverse varnish effects is generally used in advertising signs, packaging, gifts, etc. In order to produce special effects, Nocai UV printer can easily solve it.



## Varnish embossing effect

Use a UV printer to print white ink on the surface of the material. After accumulating detailed unevenness, print colored ink varnish to achieve a relief and bright effect.

The varnish embossing effect is the biggest highlight of UV, which cannot be achieved by other processes. It is used in a wide range of industries: electronic products and peripherals, handicrafts, gifts, advertising, leather goods, etc.

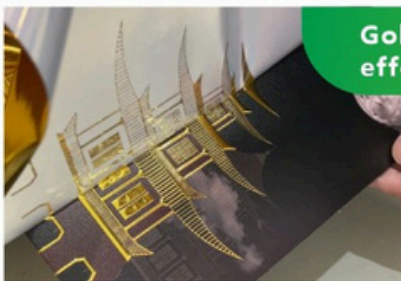

## Golden embossing effect

Golden embossing on the surface of the material, and use a laminating machine to transfer the hot stamping film to the material at high temperature to achieve the hot stamping effect.

With the demand for personalized customization, the demand for hot stamping effects has gradually increased. Product applications: gift boxes, labels, cards, etc.



## 360 degree rotation effect

The cylinder jig can be used to print on cylinder products of various shapes to achieve 360-degree curved surface printing.

The 360-degree rotation effect is mainly used in the field of personalized customization. Product applications: thermos cups, mugs, glass lamps, cylinder electronic products, etc.

## Scene requirements

### Computer configuration requirements:

- Operating system: Windows 7/8/10/11 (64 bits)
- CPU processor: recommended i5, i7 and above
- Memory: 16G or above recommended
- Monitor: Recommended resolution 1024\*1280 or higher
- Hard disk type: 128G or above
- Graphics card: Motherboard integrated graphics or independent graphics card
- (4GB video memory or above)
- Network card: Gigabit network card 1000M

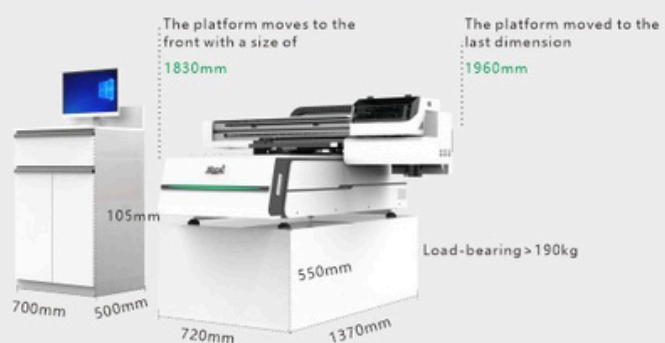

\*Computers, computer desks, and machine bases need to be self-provided

# Product parameters

Model number	NC-UV0609PEIII-II	
Printhead configuration	Epson I1600-U1*3	
Print head picture		
Nozzle spray force range	2-3mm	
Number of nozzles	1600 (Individual)	
Distance between nozzles	1/300 inch	
Number of nozzle rows	4	
Maximum number of supported ink colors	4	
Droplet ejection performance (droplet volume and ejection frequency)	2 levels of grayscale	5 pl (43.2kHz)
	3 levels of grayscale	6,12.5 pl (21.6kHz)
	4 levels of grayscale	3.8,6.2,9.3 pl (21.6kHz)
Print size	600*900mm	
Print height	0-180mm	
Print version	White,Color&Varnish	
Print mode	CMYK+W+V	
Resolution	720*900dpi / 720*1200dpi	
Printer dimension	L*W*H	1676mm*1627mm*693mm
N.W.	187KG	
Packing size	L*W*H	1.82m*1.83m*0.98m
G.W.	350KG	
Rip software	FlexiPRINT MiniServer 19 Nocai Edition	
Print speed range	1.64-5.09 square/h	
Graphic and text format	Tiff,Jpg,Eps,Pdf,Png,AI	
Connection method	Cable	
voltage	AC220V/110V±10, 50HZ~60HZ	
rated power	245W	
Working environment	Temperature	20°C-28°C
	Humidity	35%-65%
Operating conditions	Dust	Avoid dusty environments
	Illumination	Avoid direct sunlight
Ink type	Environmentally friendly UV curing ink	

## Fixture (optional)

Electric cylinder fixture		
Support cylinder diameter	Φ30-120mm	
Support cylinder length	40~430mm	
Applicable materials	Spray paint cup, stainless steel, plastic, glass, ceramic, wood, acrylic, etc.	
Round bottle printing method	C+W (Round bottle mode does not support varnish printing)	
Round bottle printing speed	3-20min/individual	
Cylindrical fixture packaging dimensions	L*W*H	68*39*14cm
Cylindrical fixture packaging weight	12KG	

